

Innowacja w oczyszczaniu powietrza procesowego



- Szwedzka firma specjalizująca się w oczyszczaniu mgły olejowej.
- Rok założenia 2002
- Ponad 100 patentów
- Zaangażowana w 40% wszystkich patentów w tej branży
- Ponad 600 klientów
- Ponad 7 000 sprzedanych separatorów
- Sprzedaż w 2011 5,5 M Euro

3nine

HQ:
Sweden

Sales Offices:

China
Finland
France
Germany
Sweden
USA

Agent/distributors:

Mexico
Spain
Hungary
Czech Republic
Italy
Norway
Polen
Slovakia
Thailand
Malaysia
Netherlands
Turkey
Japan



3nine
3nine

Linia niebieska

Rodzina produktów



C L A R A 1.000 m³/h



L I N A 500m³/h



E M M A 2.500m³/h



P E T R A 1.000m³/h

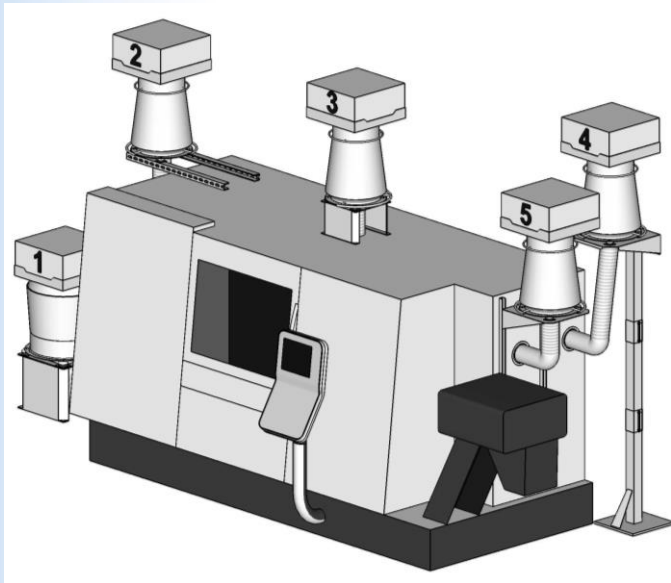

3nine

Rodzina produktów

Linia zielona



NOVA

Przepływ 300 m³/h
Kabina < 3m³



ANNA

Przepływ 600 m³/h
Kabina < 6m³



LOVA

Przepływ 900 m³/h
Kabina < 9m³



NINA

Przepływ 1 200 m³/h
Kabina < 12m³

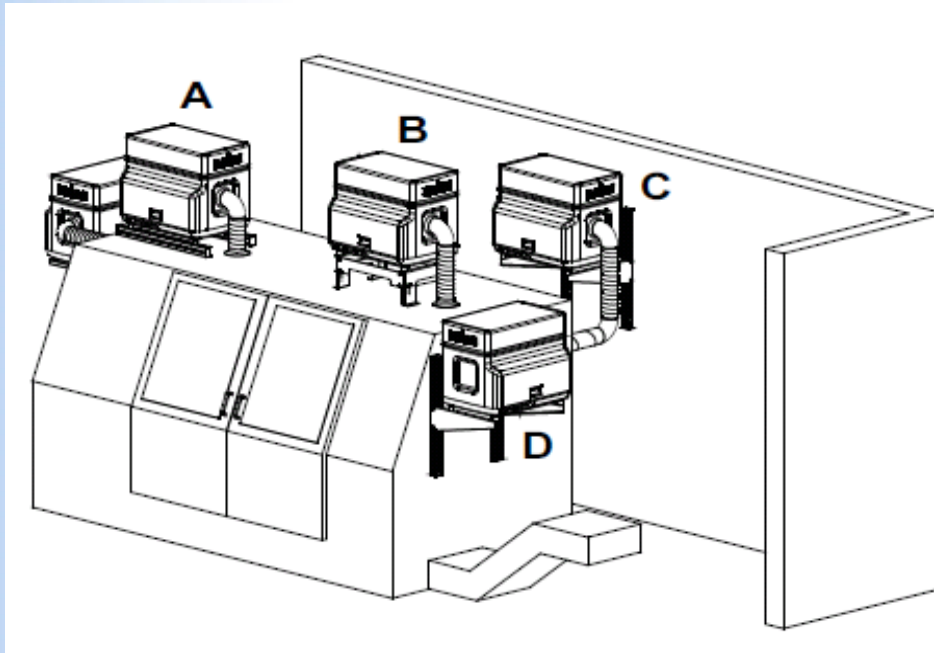

Technologia – Przekrój

Zespół ruchomych tarcz

Czyste powietrze wraca na halę

Plastikowe tarcze gromadza krople oleju i zanieczyszczenia

Czyste powietrze pomaga kroplom oleju powrót do maszyny



Olej jest gromadzony w rynience



Olej wraca do maszyny

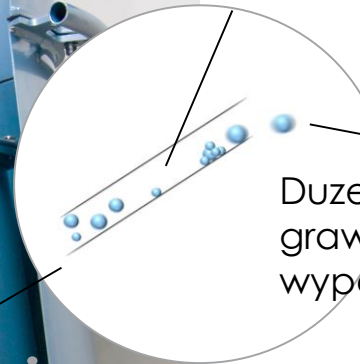

Duże krople grawitacyjnie wypadają z tarcz

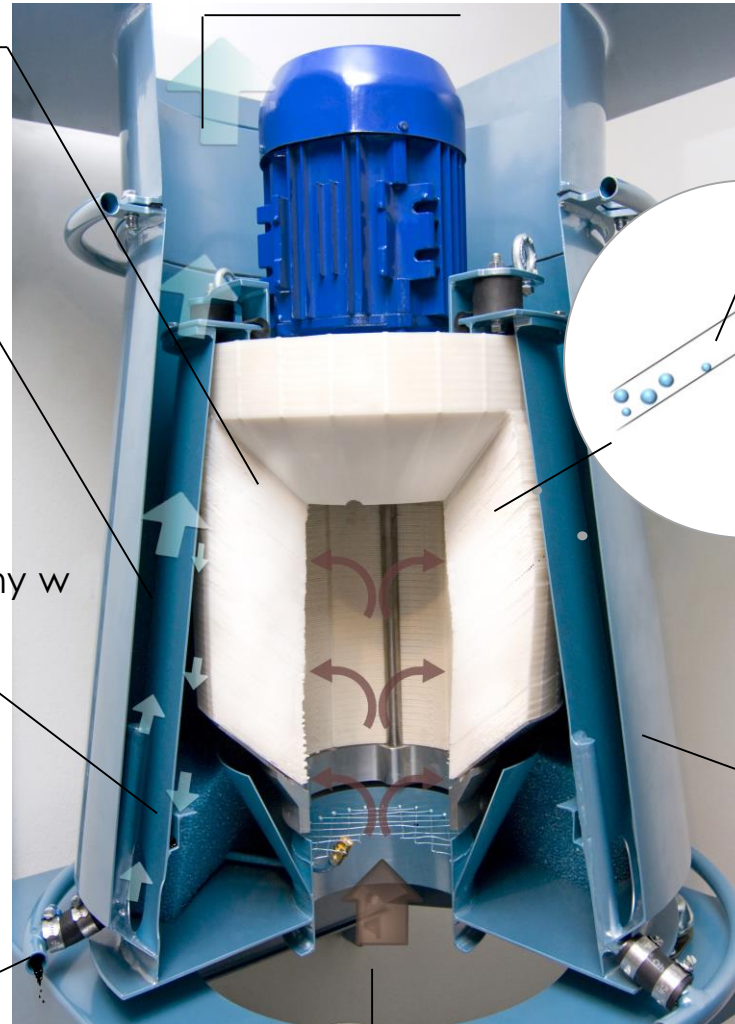

Obudowa

Mgła olejowa wciągana jest do separatora

3nine

Technologia, gwarantująca usunięcie najmniejszych cząstek

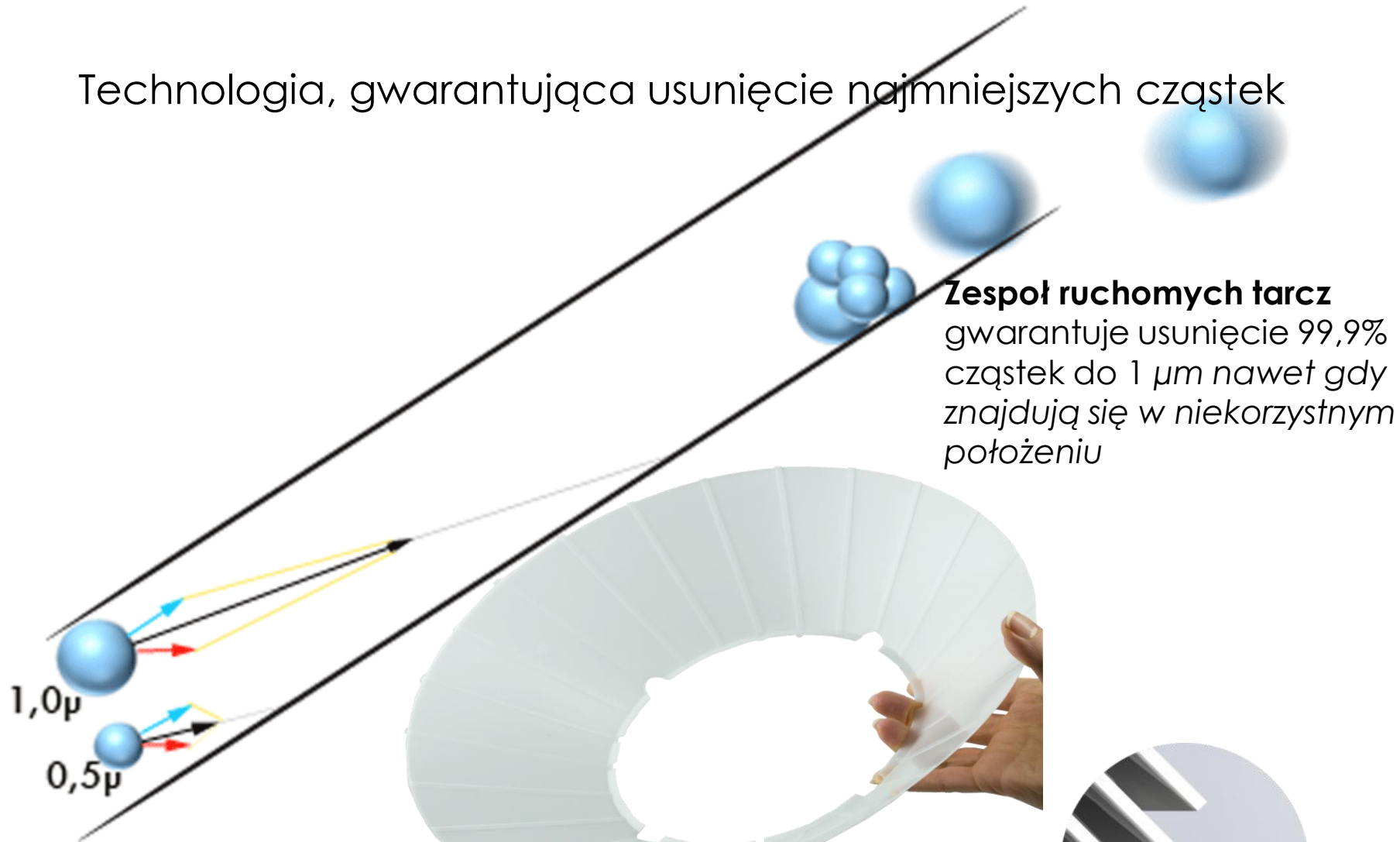

Zespół ruchomych tarcz
gwarantuje usunięcie 99,9%
cząstek do 1 µm nawet gdy
znajdują się w niekorzystnym
położeniu

1,0µ
0,5µ

Cząstki mniejsze niż 1 µm
są usuwane jeżeli ich
położenie gwarantuje
kontakt z cząstkami
większymi od 1 µm

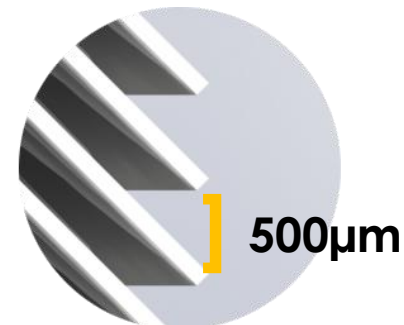

Technologia - **CIP** – *Cleaning in Place* / Czyszczenie wewnątrz

Lepkie czastki zwłaszcza podczas szlifowania lub obróbki żeliwa mogą przyklejać się do wewnętrznej powierzchni

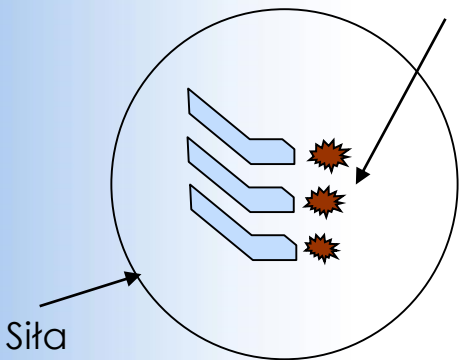

Siła odśrodkowa wyrzuca wszystkie elementy stałe

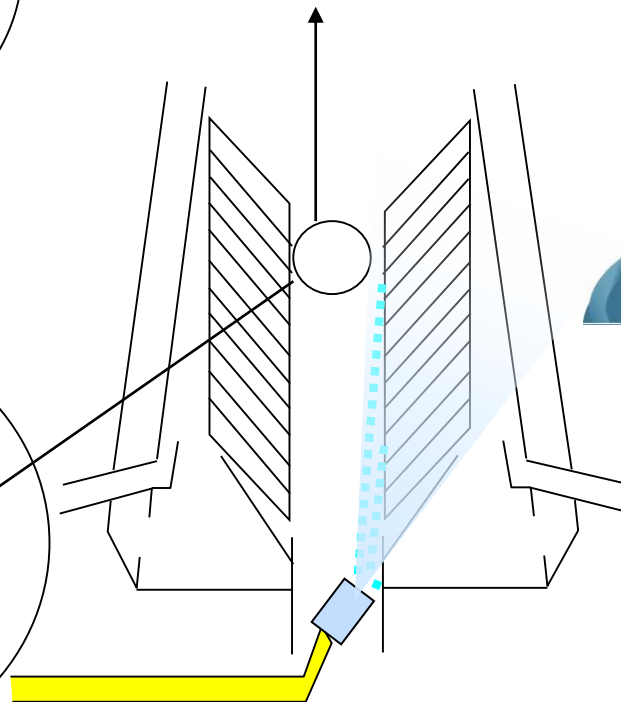
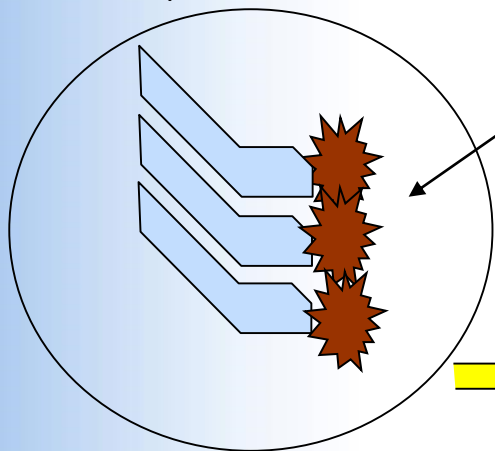

W celu uniknięcia blokowania 3nine opatentowało technologie czyszczenia



99.9%
of all the fluid particles are extracted from the air

3nine

Nagrodzona w kategorii
Bezpieczne użytkowanie

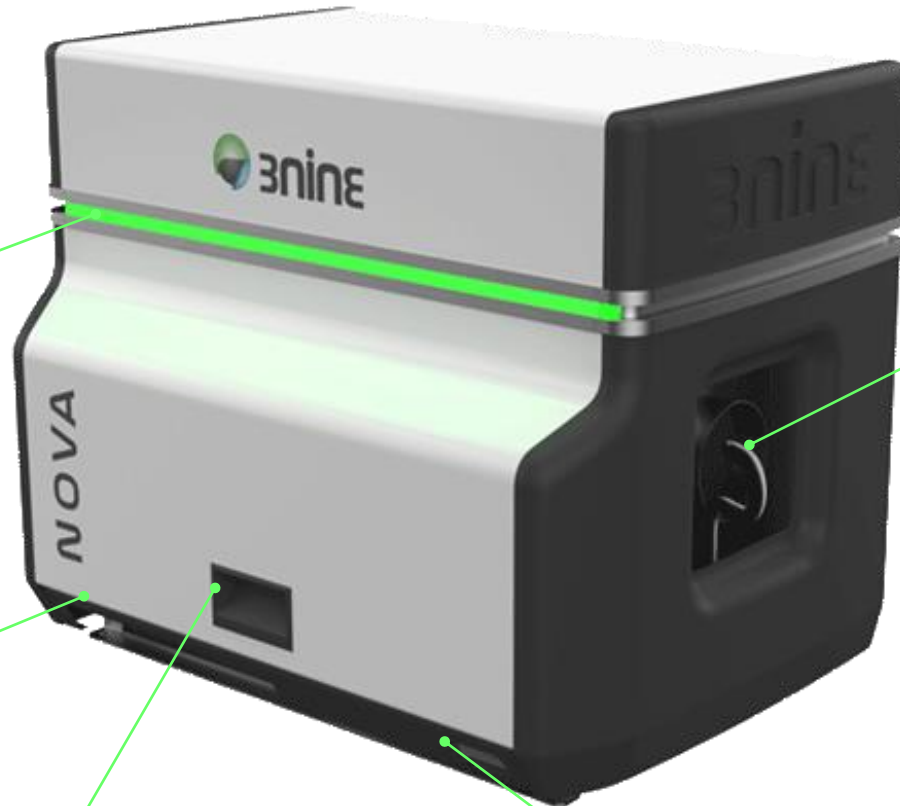

LED system komunikacji

CIP System czyszczący

Czyste powietrze

Prosta wymiana filtra

Powrót oleju do maszyny

Award winning product at the salon industrie Paris 2012



znine

Zasada działania

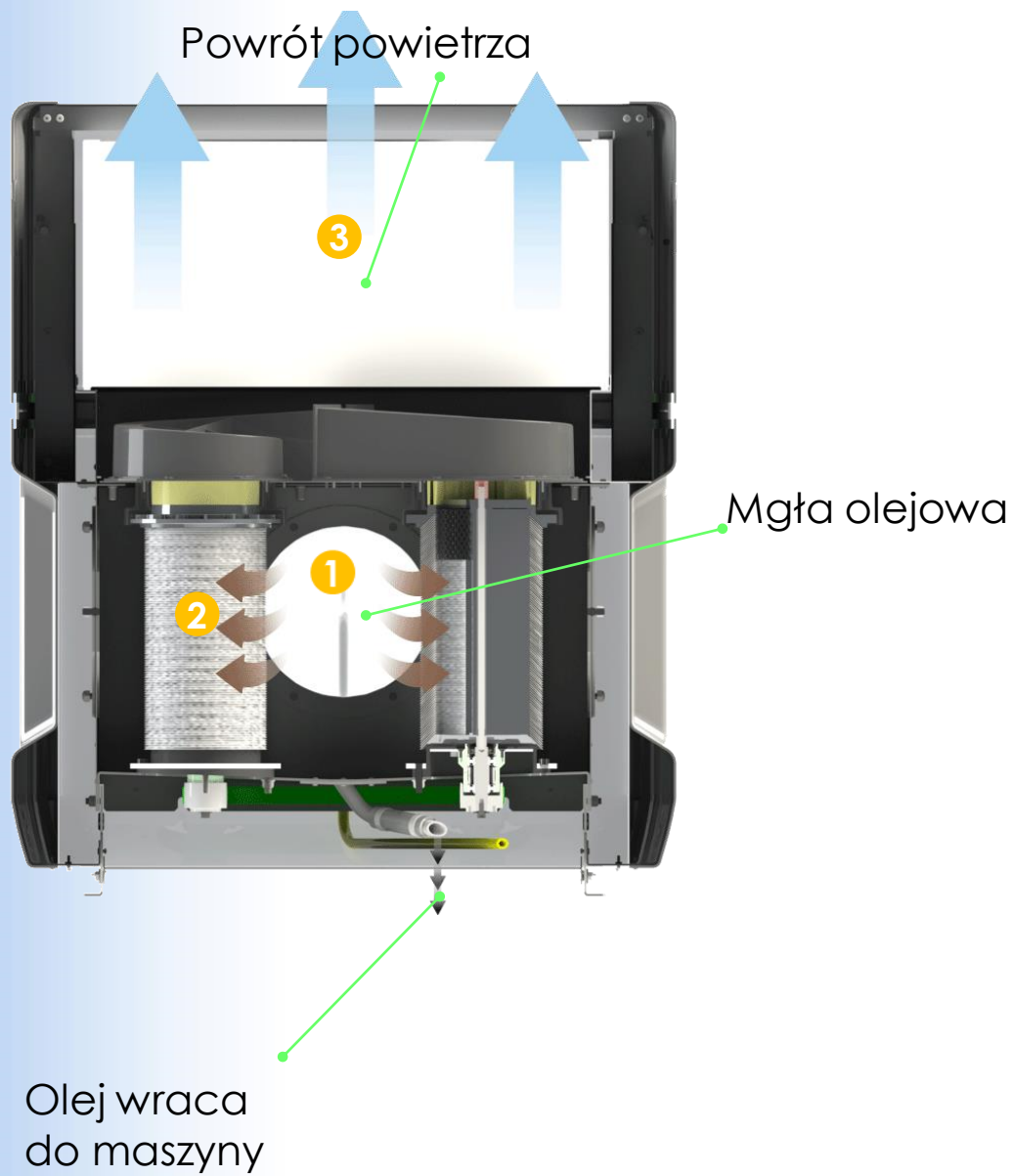

- 1 Kierunkowy przepływ
Eliminuje cząstki $> 10 \mu\text{m}$.
- 2 System tarcz
Eliminuje cząstki $> 1 \mu\text{m}$
- 3 HEPA filter
Eliminuje cząstki $< 1 \mu\text{m}$

Technologia kierunkowego przepływu

Motor napędzający wirnik generuje podciśnienie

Obracający element eliminuje cząstki > 10 μm zaraz po wejściu do separatora

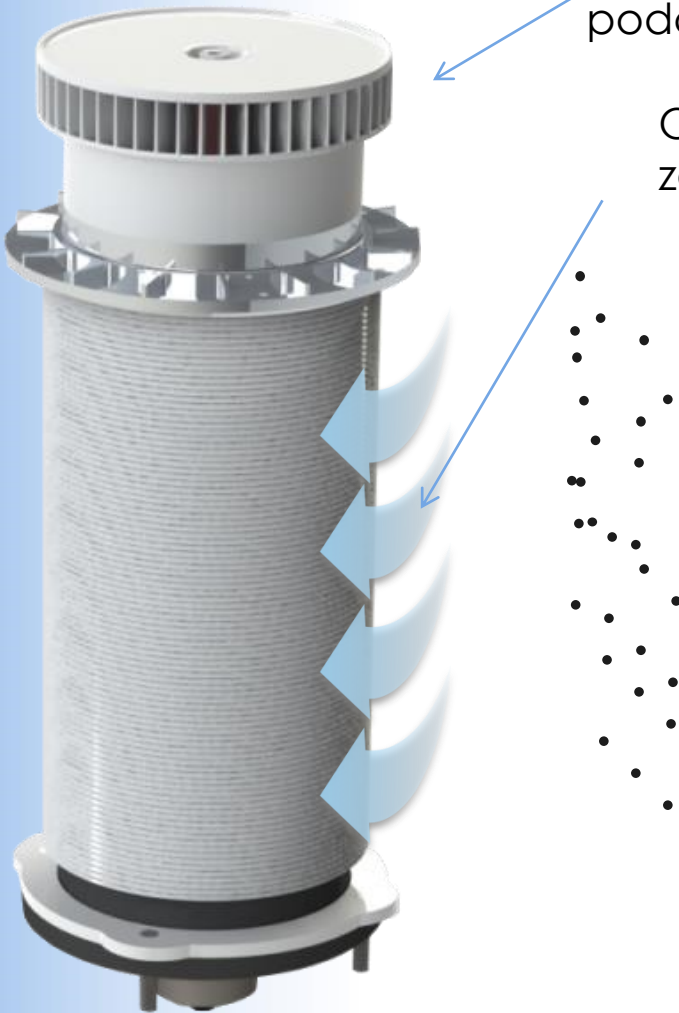

Bnine

Mgła olejowa – Niezależne testy *

Usunięte zanieczyszczenia
%

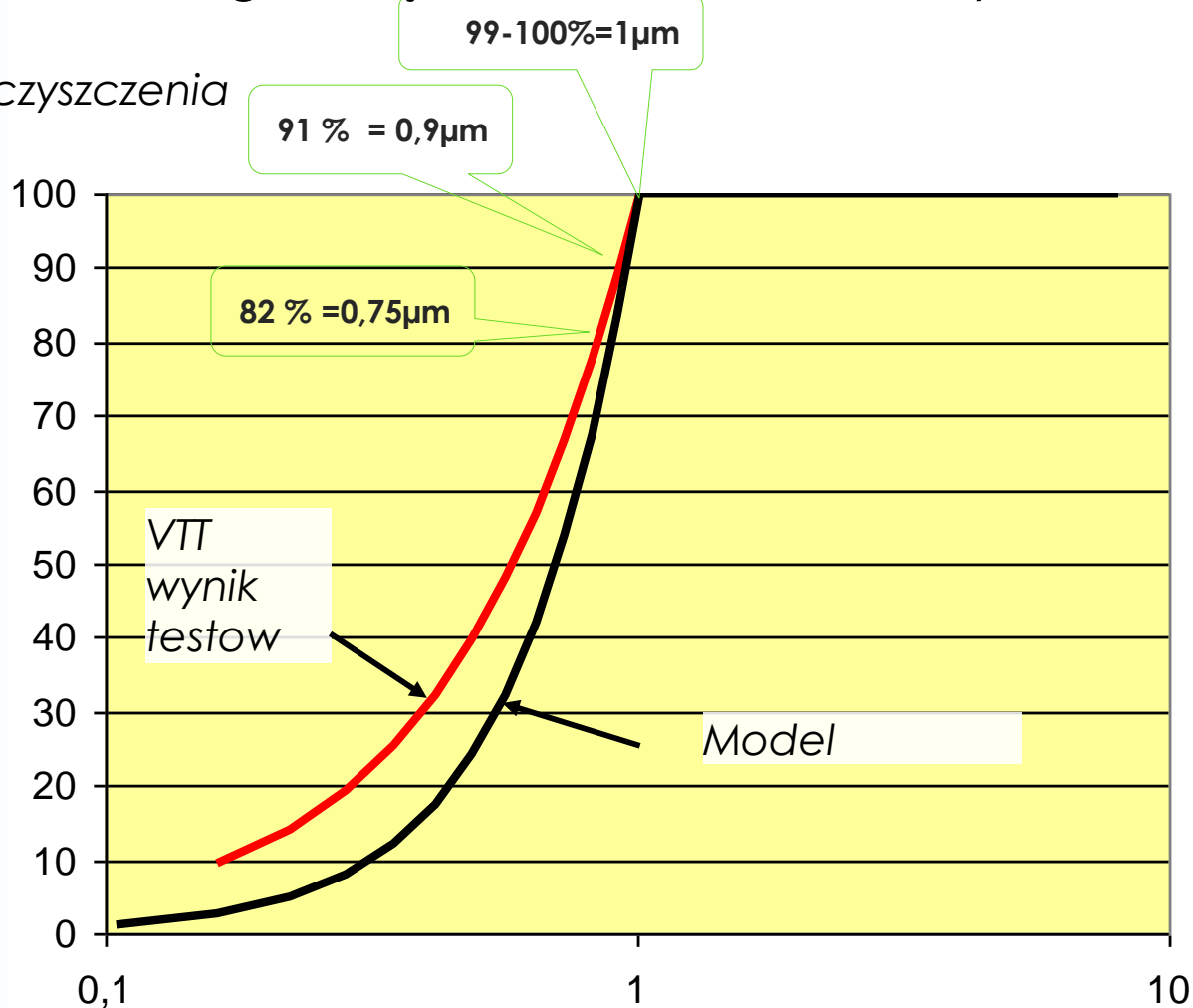

Wymiary
(μm)

* VTT: Finnish state test institute



Krzywe rozkładu mgły olejowej

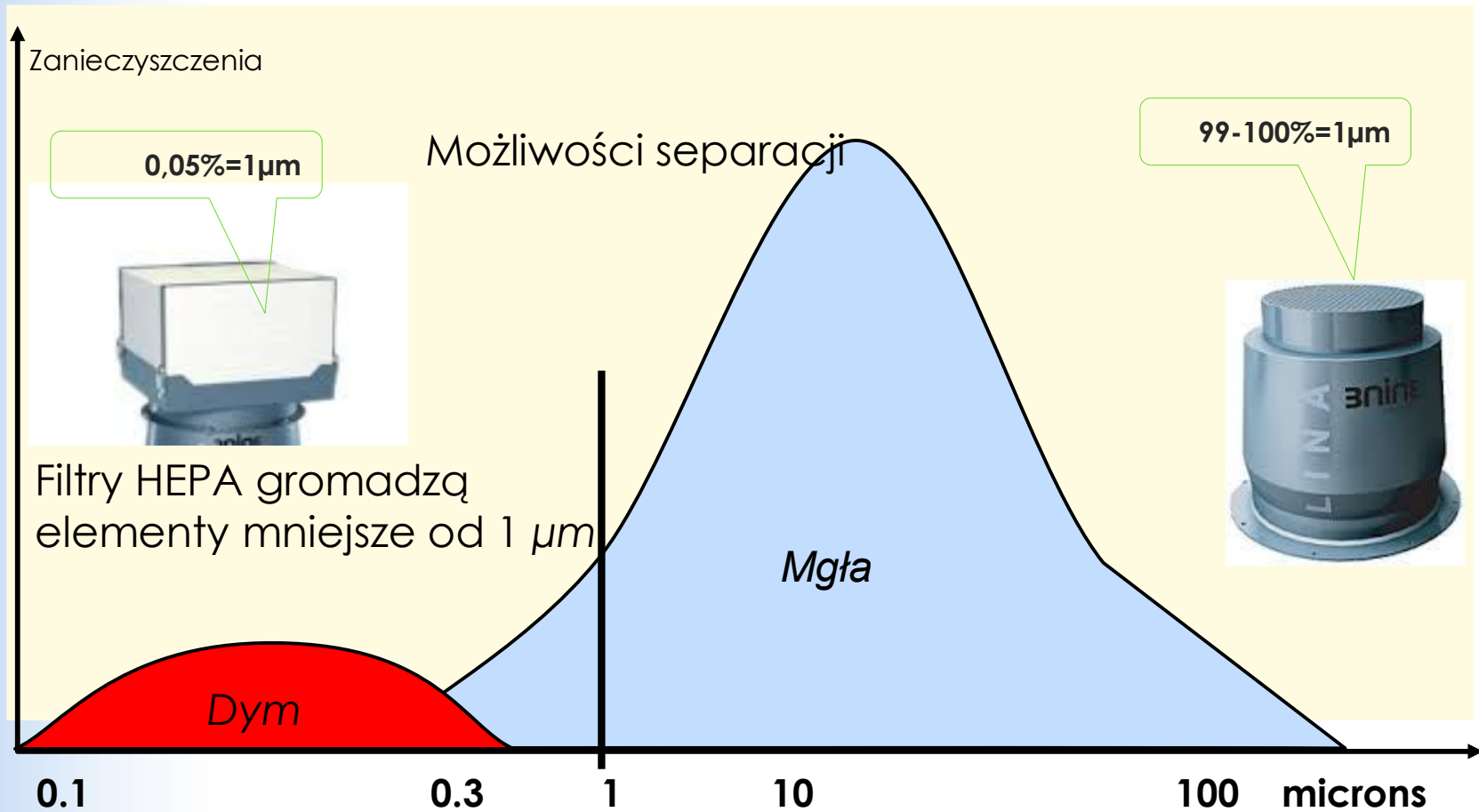



ANNA
Mazak



NOVA
Okuma



NOVA
Mazak



Mazak MAZATECH FH-6800

STACKE HYDRAULIK Skillingaryd







DMC 100 U

DMC 100 B
DYNAMIC MACHINING





DMU 80 T
DECKER MAHO

Oszczędności – Gdzie ucieka chłodziwo?



Oszczędności - Czy znajdziemy je w pojemnikach?

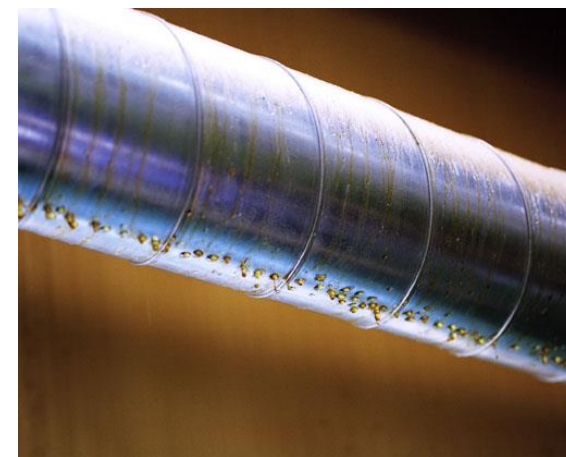
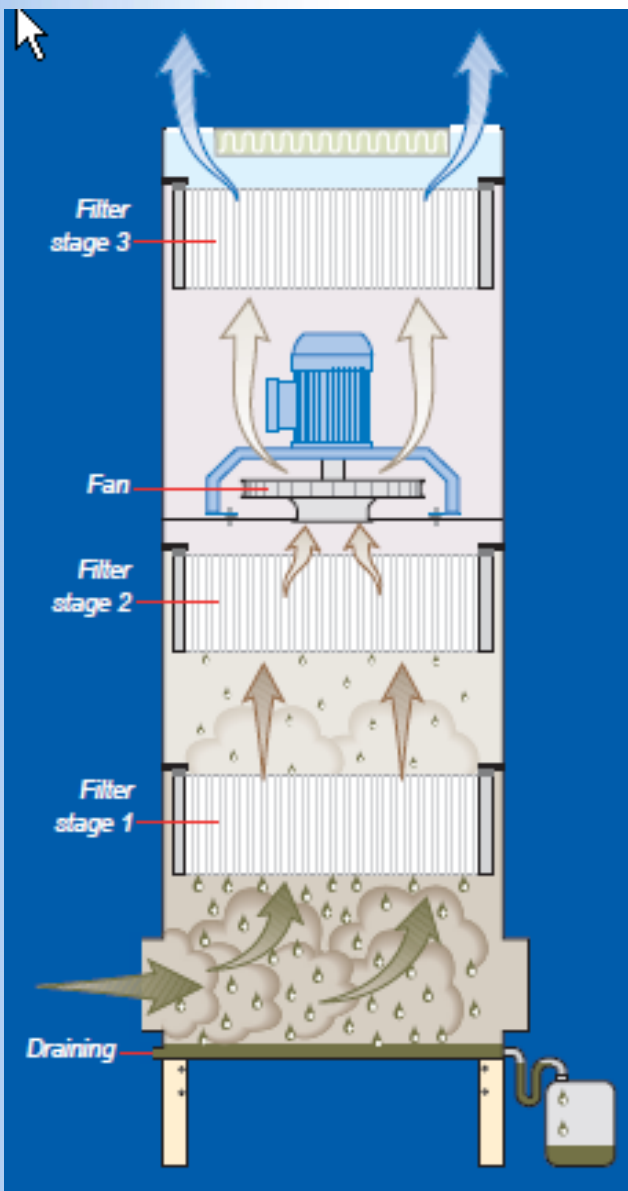

3nine

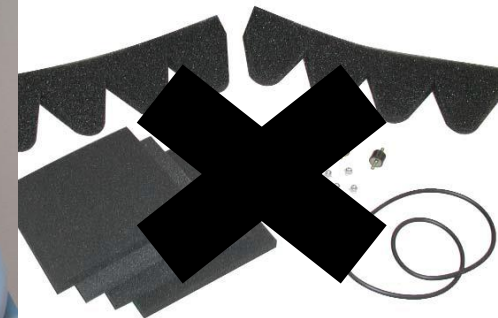
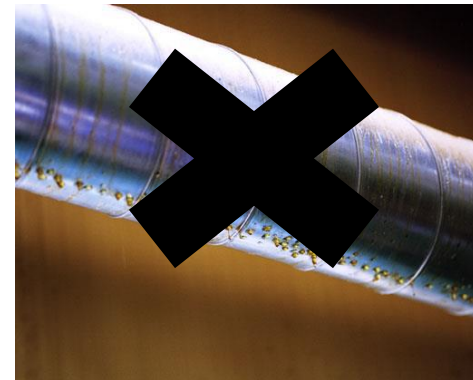
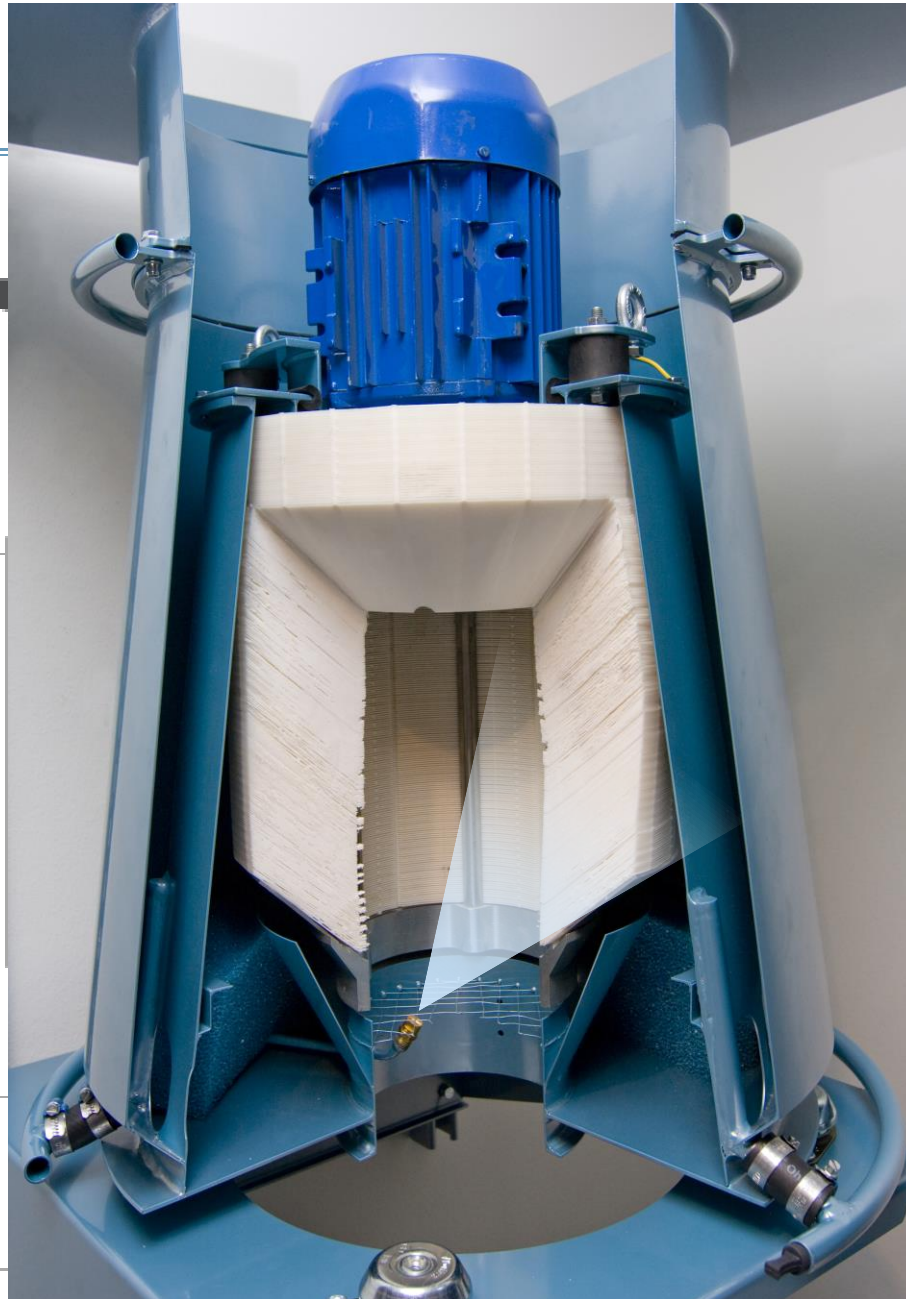

3nine

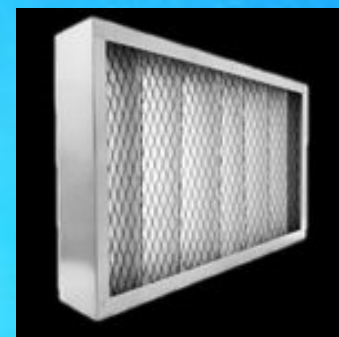
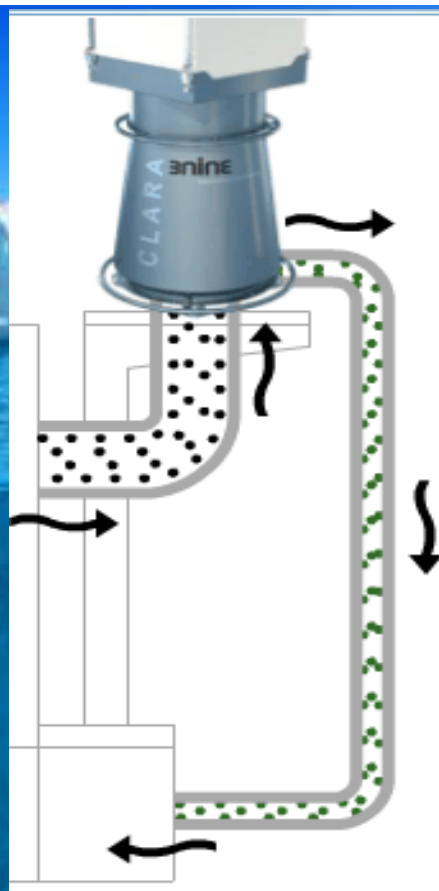

Producenci filtrów czasami pomijają koszty związane z konserwacją myciem, wymianą filtrów na rzeczywisty koszt użytkowania!!



Separacja czy gromadzenie?



$1\ 000\ m^3/h \times 100\ mg/m^3$

1 zmiana 8 h = 0,8 kg/dzień

3 zmiany 8 h = 2,4 kg/dzień

365 dni = 876 kg/rok



Separacja to
oszczędność

Gromadzenia
to strata

Czy rozważali państwo zmianę?

3nine

Klienci Globalni

DENSO



BOSCH



KONECRANES
Lifting Businesses™

SECO

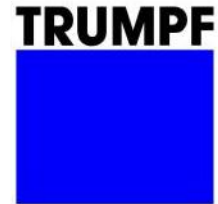

Freude am Fahren



MARIFF
AUTC Fire & Security Company

PSA PEUGEOT CITROËN



GETRAG

SCANIA

brembo SGL GROUP
CARBON CERAMIC BRAKES

SAFRAN
Messier-Bugatti-Dowty



VALTRA

ABB

SIEMENS



PORSCHE

3nine

Klienci Polska

TIMKEN



B/S/H/



UNI WHEELS®
UNITED WHEELS GROUP

spinko

BorgWarner

KFLT
KRAŚNIK

neapco



Volkswagen



Pratt & Whitney

A United Technologies Company

FABRYKA ŁOŻYSK TOCZNYCH
nexteer
AUTOMOTIVE



SAFRAN

Hispano-Suiza Polska

Konsultacje/ Testy



WSK „PZL-Rzeszów” S.A.

DAYCO

thoni
ALUTEC

MAGNETI
MARELLI

EATON

Powering Business Worldwide

SKF



GKN
GKN Driveline

NSK
Steering Systems Europe Polska

FEDERAL
MOGUL

3nine

Oszczędności dla Państwa



Czyszczenie



Wymiana

3nine

Mechanical Filter

Electrostatic Filter

Rotating Filter

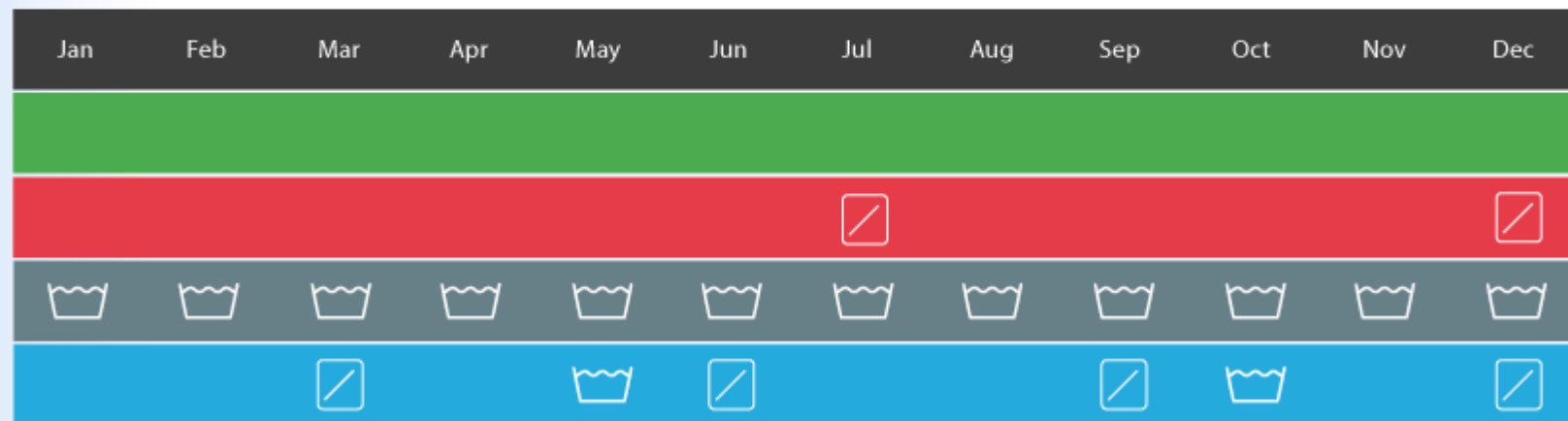

Zapraszamy do przeanalizowania naszej propozycji !



Gromadzenia vs Separacja

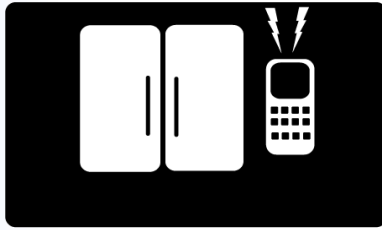

GROMADZENIE



SEPARACJA



Obrotowy



Mechaniczny



Elektrostatyczny



3nine

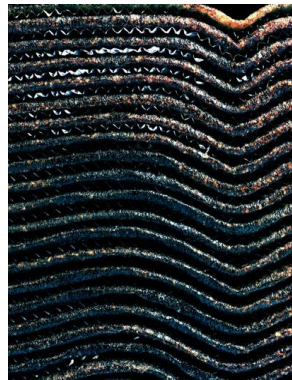

3nine